

1 2 3 4 5 6 7 8

REVISIONS		
ISS	ZONE	DESCRIPTION\PER REQUEST\DATE

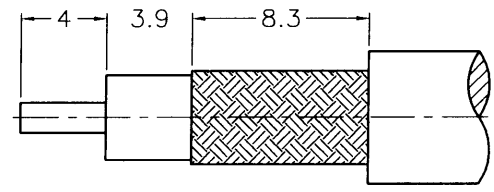

RECOMMENDED  
CABLE STRIPPING DIM'S  
(建議剝線尺寸)

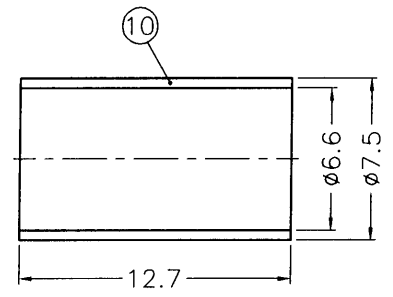
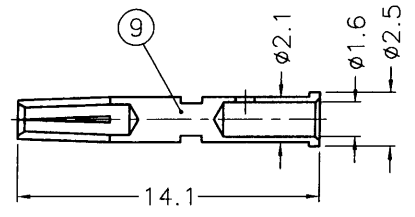
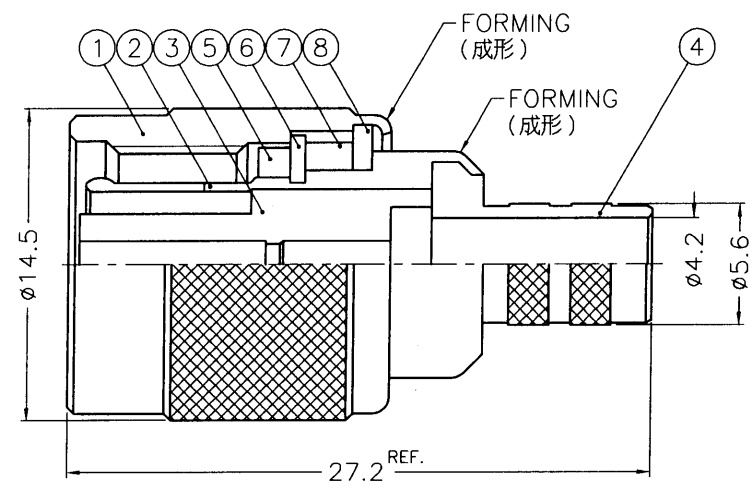

- NOTES: FINISH (PLATING THICKNESS IN MICRO-INCHES)
- 1. BRASS PER QQ-B-626
  - 2. BRASS PER QQ-B-613
  - 3. NICKEL PL. 100 MIN. THICK OVER COPPER STRIKE
  - 4. PHOSPHOR BRONZE PER QQ-B-750
  - 5. GOLD PL. 3 MIN. THICK OVER NICKEL PL. 100 MIN. THICK OVER COPPER STRIKE
  - 6. TEFLON MIL-P-19468
  - 7. JIS H 3250, C 2700

- 1. CRIMPED FERRULE  
HEX CRIMP SIZE .255"
- 2. CRIMPED CONTACT PIN  
HEX CRIMP SIZE .068"

10	FERRULE	NOTE 7	NOTE 3	1	FR-75/66X127
9	CONTACT PIN	NOTE 4	NOTE 5	1	B74000-8-25/16
8	WASHER	NOTE 2	NOTE 3	1	WS-128/9X08
7	RING	DELTRIN	NATURAL	1	T50000-6-A
6	RETAINER RING	NOTE 1	NOTE 3	1	B50000-5
5	GASKET	RUBBER	RED	1	GS-105/8X15
4	BARREL	NOTE 1	NOTE 3	1	B50900-6-56/42
3	INSULATOR	NOTE 6	NATURAL	1	RB1121A1-3T-50
2	BODY	NOTE 1	NOTE 3	1	RB1121A1-2
1	SHELL	NOTE 1	NOTE 3	1	T50000-1-B
NO.	DESCRIPTION	MATERIAL	FINISH	Q'TY	DRAWING NO.

DIMENSIONS ARE IN MILLIMETERS  
UNLESS OTHERWISE SPECIFIED  
TOLERANCES  
0.5-6 = ±0.2  
6-30 = ±0.4  
30-120 = ±0.6  
120-315 = ±1  
315-1000 = ±1.6  
1000-2000 = ±2.4

PART NO.	
APPROVED	DATE
	11-04-99'
CHECKED	DATE
	11-04-99'
DRAWN	DATE
	11-04-99'

ADA

Amphenol - Kai Jack	
TAINAN TAIWAN	
TITLE	TNC CRIMP REVERSE PLUG
DRAWING NO.	KJ-RT1121A1-NT3G-8X-50
FILE NO.	F:\DWG\RT\1121A1\8X-50\NT3G

A

A

1 2 3 4 5 6 7 8